

PA-S70W

CNC-Control

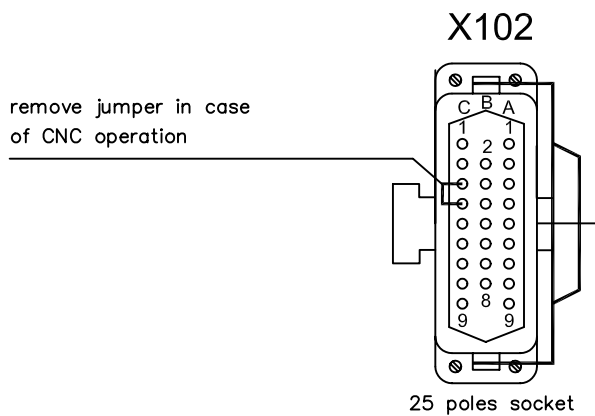
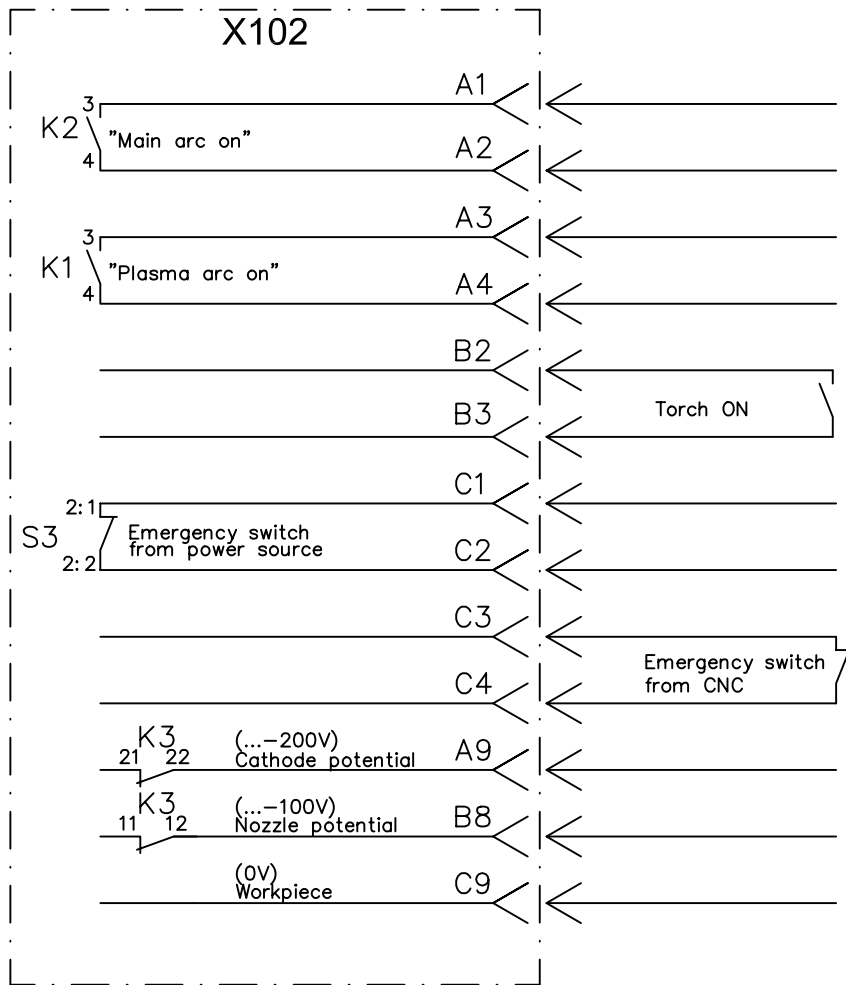

valid from:

Verwendungsbereich			zul. Abw.		Oberfl.		Maszstab		Masse		
							Werkstoff, Halbzeug				
			Datum		Name		Benennung				
			bearb. 06.06.03		Jagieniak		Wiring diagram PA-S70W CNC-Interface X102				
			gepr.								
			Norm								
					Zeichn.-Nr. .11.033.802.SP2 a		Blatt				
							Bl.				
Zust Aenderung		Datum		Name		Urspr.		Dok/PA-S70W/SP2a			